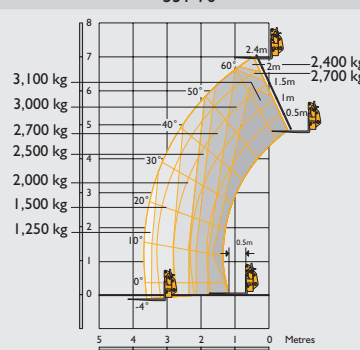
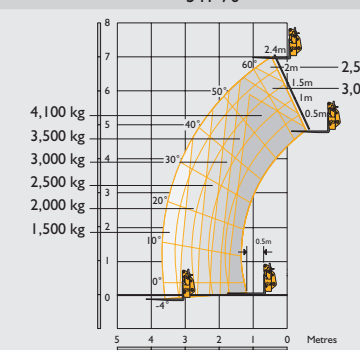
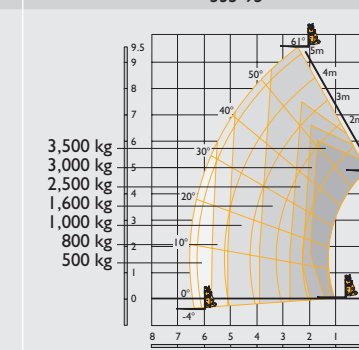

STATIC DIMENSIONS

Machine model		531-70	541-70	535-95	533-105	535-125 HiViz	535-140 HiViz	540-140	540-170
A	Overall height	m	2.49	2.49	2.49	2.59	2.59	2.59	2.69
B	Overall width (over tyres)*	m	2.23	2.23	2.36	2.36	2.35	2.35	2.44
C	Inside width of cab	m	0.94	0.94	0.94	0.94	0.94	0.94	0.94
D	Front track	m	1.81	1.81	1.87	1.87	1.90	1.90	1.90
E	Wheelbase	m	2.75	2.75	2.75	2.75	2.75	2.90	2.75
F	Overall length to front tyres	m	4.38	4.38	4.38	4.38	4.74	4.74	5.08
G	Overall length to front carriage	m	4.99	4.99	4.99	5.38	5.80	6.23	6.36
H	Ground clearance	m	0.40	0.40	0.40	0.40	0.40	0.40	0.40
J	Front wheel centre to carriage	m	1.25	1.25	1.20	1.62	1.68	2.11	1.65
K	Rear wheel centre to rear face	m	0.99	0.99	1.04	1.01	1.37	1.37	1.67
	Overall width with stabilisers fully deployed	m	NA	NA	NA	2.63	2.57	2.57	3.55
	Outside turn radius (over tyres)	m	3.7	3.7	3.7	3.7	3.75	3.75	4.10
	Carriage rollback angle	degrees	42.6	42.6	41.0	41.2	37.0	37.0	39
	Carriage dump angle	degrees	37.5	37.5	24.0	24.0	12.5	12.5	8.8
	Weight	kg	7060	7850	8215	8850	9720	10880	12060
	Tyres		15.5/80-24	15.5/80-24	15.5/80-24	15.5/80-24	15.5/80-24	15.5/80-24	15.5/80-24

* Type Dependent

LIFT PERFORMANCE

		531-70	541-70	535-95
				
Maximum lift capacity	kg	3170	4100	3500
Lift capacity to full height	kg	2400	2500	1600
Lift capacity at full reach	kg	1250	1500	500
Lift height	m	7.0	7.0	9.50
Reach at maximum lift height	m	0.48	2.94	2.43
Maximum forward reach	m	3.7	3.7	6.52
Reach with 1 tonne load	m	3.7	3.7	5.08
Placing height	m	6.3	6.3	8.78

Complies with stability test EN 1459 Annex B.

LIFT PERFORMANCE

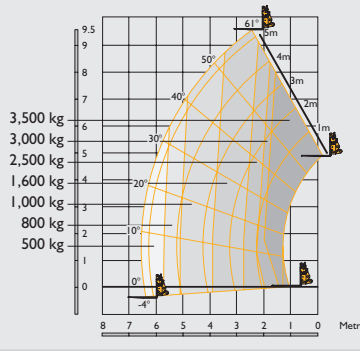
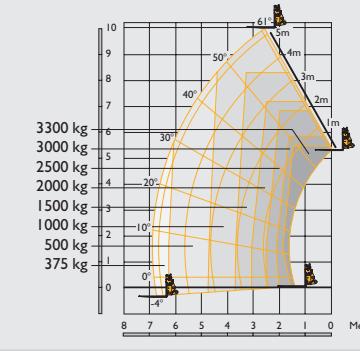
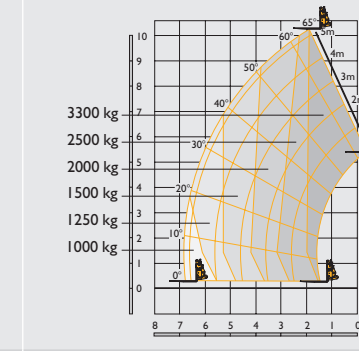
		535-95 Sway	533-105 Stabilisers retracted	533-105 Stabilisers extended
				
Maximum lift capacity	kg	3500	3300	3300
Lift capacity to full height	kg	1600	1000	3300
Lift capacity at full reach	kg	500	375	1000
Lift height	m	9.50	9.85	10.22
Reach at maximum lift height	m	2.43	2.63	1.91
Maximum forward reach	m	6.52	6.91	6.83
Reach with 1 tonne load	m	5.08	4.83	6.83
Placing height	m	8.78	9.44	9.82

Complies with stability test EN 1459 Annex B.

LIFT PERFORMANCE

	535-125 HiViz Stabilisers retracted	535-125 HiViz Stabilisers extended	535-140 HiViz Stabilisers retracted	535-140 HiViz Stabilisers extended
Maximum lift capacity	kg	3500	3500	3500
Lift capacity to full height	kg	1500	3500	3000
Lift capacity at full reach	kg	200	1150	1250
Lift height	m	12.28	12.07	13.78
Reach at maximum lift height	m	1.36	0.46	0.93
Maximum forward reach	m	8.10	8.06	9.70
Reach with 1 tonne load	m	5.31	8.06	6.61
Placing height	m	11.43	11.75	13.02

Complies with stability test EN 1459 Annex B. Chassis Levelling (Sway) with stabilisers retracted (Sway angle ±9°).

LIFT PERFORMANCE

	540-140 Stabilisers retracted	540-140 Stabilisers extended	540-170 Stabilisers retracted	540-170 Stabilisers extended
Maximum lift capacity	kg	4000	4000	4000
Lift capacity to full height	kg	2000	4000	2500
Lift capacity at full reach	kg	200	1250	0
Lift height	m	12.82	13.8	11.57
Reach at maximum lift height	m	2.94	0.74	4.15
Maximum forward reach	m	9.25	9.25	9.04
Reach with 1 tonne load	m	6.25	9.25	5.76
Placing height	m	12.25	13.25	10.90

Complies with stability test EN 1459 Annex B.

ENGINE								
	531-70	541-70	535-95	533-105	535-125 HiViz	535-140 HiViz	540-140	540-170
Engine 63kW (58hp) @ 2200rpm, 400Nm torque at 1300rpm	Standard	Standard	Standard	Standard	Standard	Standard	Standard	N/A
Engine 74kW (100hp) @ 2200rpm, 512Nm torque at 1300rpm	Option	Option	Option	Option	Option	Option	Option	Standard
Engine 97kW (130hp) @ 2200rpm, 550Nm torque at 1300rpm	Option	Option	Option	Option	Option	Option	Option	Option

HYDRAULIC CYCLE TIMES									
	531-70	541-70	535-95	533-105	535-125 HiViz	535-140 HiViz	540-140	540-170	
Boom raise	s	7.2	8.8	9.1	8.8	10.4	13.5	15.1	22.7
Boom lower	s	5.4	6.5	7.7	8.5	8.1	11	15.5	23.4
Extend	s	6.8	6.8	10.5	13.2	15.7	15.6	19.5	18.3
Retract	s	5	5	11.2	13.6	12.8	14.4	19.2	16.7
Bucket dump	s	3.5	3.5	2.4	2.4	1.8	1.7	3.2	4.2
Bucket crowd	s	2.9	2.9	3.5	3.4	2.3	2.0	2.5	4.6

HYDRAULICS		
	Hydraulic System Pressure (bar)	Max. Pump flow (litres)
531-70	241	82
541-70	260	82
550-80	260	140
535-95	241	82
533-105	241	82
535-125	260	260
535-140	110	110
540-140	241	103
540-170	260	90+72

TRANSMISSION	Torque converter, 4 speed powershift gearbox. Travel speed 531-70/541-70/535-95/533-105: 29kph, 33kph (when 2/4WD select is specified). Travel speed 535-125/535-140 540-140/540-170: 29kph. Optional 33kph transmission.
BRAKING	Service brake: Servo-assisted, hydraulically oil-immersed multi-disc on front and rear axle. Parking brake: Hand operated disc brake on output of gearbox. (97kW/130hp – oil immersed disc type).
CAB	Conforms to ROPS ISO 3471 and FOPS ISO 3449
OPTIONS	Front and rear working lights, rotating flashing beacon, fire extinguisher, traction and industrial tyres, electrical 2/4WD select, limited slip differential in front axle, windscreen and roof guard, air suspension seat, deluxe cab trim, roof and front screen blind, radio kit, air conditioning, reversing fan, deluxe trim, armrest (SLC only), roof moulding, single lever control (model dependant). Single lever mechanical joystick, with push button extend and retract.